

KLM Technology Group Practical Engineering Guidelines for Processing Plant Solutions	 www.klmtechgroup.com	Page : 1 of 58
		Rev: 03 Rev 2 - APRIL 2007 Rev 3 – Novmeber 2010
KLM Technology Group #03-12 Block Aronia, Jalan Sri Perkasa 2 Taman Tampoi Utama 81200 Johor Bahru	INSTRUMENTATION (ENGINEERING DESIGN GUIDELINE)	Author: Rev 01 - A L Ling Rev 02 - A L Ling Rev 03 – Viska Mulyandasari
		Checked by: Karl Kolmetz

TABLE OF CONTENT

INTRODUCTION

Scope	6
General Instrumentation Consideration	7
Pneumatic Power Supplies	8
Important of Instrumentation Control for Unit Operation	9
Process Variable Measurement Instrument	10

DEFINITIONS

12

NOMENCLATURE

14

THEORY

A) Pressure Measurement	16
Height of a Liquid Column	16
Elastic-Element – Bourdon Tube, Bellows and Diaphragm	18
i) Bourdon Tubes	19
ii) Bellows	20
iii) Diaphragm	22
Electrical Method -Electrical Pressure Transducers	23

KLM Technology Group Practical Engineering Guidelines for Processing Plant Solutions	SECTION : INSTRUMENTATION (ENGINEERING DESIGN GUIDELINE)	Page 2 of 58
		Rev: 03
		November 2010

i) Strain Gauges	23
B) Level Measurement	24
Gauge Glass	25
Chain or Tape Float Gauges	26
Lever and Shaft Float Gauges (Ball Gauge)	27
Displacer	29
Pressure Gauge	32
Electrical Level Gauges	35
Magnetic Gauge	36
C) Temperature Measurement	37
Thermocouples	37
i) Thermocouples Sensor	40
Resistance Thermometers (RTD)	41
Bimetal Thermometers	42
D) Signal Transmitter	43
E) Recorders and Indicators	44
F) Control System	44
G) Control Modes and Controllers	45
On-off Controller	45
Proportional Controller	46
Proportional Plus Integral (PI)	47

These design guideline are believed to be as accurate as possible, but are very general and not for specific design cases. They were designed for engineers to do preliminary designs and process specification sheets. The final design must always be guaranteed for the service selected by the manufacturing vendor, but these guidelines will greatly reduce the amount of up front engineering hours that are required to develop the final design. The guidelines are a training tool for young engineers or a resource for engineers with experience.

This document is entrusted to the recipient personally, but the copyright remains with us. It must not be copied, reproduced or in any way communicated or made accessible to third parties without our written consent.

KLM Technology Group Practical Engineering Guidelines for Processing Plant Solutions	SECTION : INSTRUMENTATION (ENGINEERING DESIGN GUIDELINE)	Page 3 of 58
		Rev: 03
		November 2010

Proportional Plus Derivative Mode (PD)	48
Proportional Plus Integral Plus Derivative (PID)	48
APPLICATION	
Example Case 1: Level Control Schematic Drawing for Fractionation Tower Bottom.	50
Example Case 2: Pressure Control Schematic Drawing for Fractionation Overhead Drum.	51
Example Case 3: Temperature Control Schematic for Bottom Fractionation Tower	52
REFERENCES	
	53
SPECIFICATION DATA SHEET	
Instrument Specification Data Sheet Revision 01	54
CALCULATION SPREADSHEET	
U-Tube Manometer Calculation Spreadsheet Revision 01	55
Level- Pressure Gauge Calculation Spreadsheet Revision 01	56
Level- Pressure Gauge (HTG) Calculation Spreadsheet Revision 01	57
Temperature- Bimetal Thermometer Calculation Spreadsheet Revision 01	58
LIST OF TABLE	
Table 1: Properties of Typical Type of Thermocouples.	39
Table 2: Metals Properties for RTDs.	42

These design guideline are believed to be as accurate as possible, but are very general and not for specific design cases. They were designed for engineers to do preliminary designs and process specification sheets. The final design must always be guaranteed for the service selected by the manufacturing vendor, but these guidelines will greatly reduce the amount of up front engineering hours that are required to develop the final design. The guidelines are a training tool for young engineers or a resource for engineers with experience.

This document is entrusted to the recipient personally, but the copyright remains with us. It must not be copied, reproduced or in any way communicated or made accessible to third parties without our written consent.

KLM Technology Group Practical Engineering Guidelines for Processing Plant Solutions	SECTION : INSTRUMENTATION (ENGINEERING DESIGN GUIDELINE)	Page 4 of 58
		Rev: 03
		November 2010

LIST OF FIGURE

Figure 1: Simple Instrument Model	7
Figure 2: U- Shape Tube Manometer	17
Figure 3: Inclined U-Tube Manometer	18
Figure 4: C-spring Bourdon-Tube Pressure Gauge	20
Figure 5: Spring-Loaded Bellows	21
Figure 6: Unopposed Bellows	21
Figure 7: Beam Balance Sensor Bellows	22
Figure 8: Diaphragm Pressure Elements	23
Figure 9: The Wheatstone bridge	24
Figure 10: Reflex Gauge Glass	26
Figure 11: Transparent Gauge Glass	26
Figure 12: Chain and Tape Float Gauge	27
Figure 13: External Ball Float Level Device for Emergency and Alarm Services	28
Figure 14: Internal Ball Float Level Device	29
Figure 15: Displacer Level Measuring Device	30
Figure 16: Quantities of a solid body immersed into a liquid	30
Figure 17: Typical pressure gauge level measurement system	33
Figure 18: HTG Level Measurement System	33
Figure 19: Bubble Tube Level Measurement	34

These design guideline are believed to be as accurate as possible, but are very general and not for specific design cases. They were designed for engineers to do preliminary designs and process specification sheets. The final design must always be guaranteed for the service selected by the manufacturing vendor, but these guidelines will greatly reduce the amount of up front engineering hours that are required to develop the final design. The guidelines are a training tool for young engineers or a resource for engineers with experience.

This document is entrusted to the recipient personally, but the copyright remains with us. It must not be copied, reproduced or in any way communicated or made accessible to third parties without our written consent.

KLM Technology Group Practical Engineering Guidelines for Processing Plant Solutions	SECTION : INSTRUMENTATION (ENGINEERING DESIGN GUIDELINE)	Page 5 of 58
		Rev: 03
		November 2010

Figure 20: Conductivity Level Device – Low and High Level Alarm Indication	35
Figure 21: Magnetic Gauge Level Measurement Device	36
Figure 22: Thermal EMF, E, of Commonly Used Thermocouples as a Function of Temperature	38
Figure 23: Typical Thermocouple circuit	39
Figure 24: Industrial Thermocouple Assembly	40
Figure 25: Ceramic Platinum RTD.	41
Figure 26: Flat Strip Bimetal Thermometer	42
Figure 27: Controller Modeling Diagram	46
Figure 28: Response of Step Change in Disturbance with Tuned P, PI, PID, and Non-controlled.	49

These design guideline are believed to be as accurate as possible, but are very general and not for specific design cases. They were designed for engineers to do preliminary designs and process specification sheets. The final design must always be guaranteed for the service selected by the manufacturing vendor, but these guidelines will greatly reduce the amount of up front engineering hours that are required to develop the final design. The guidelines are a training tool for young engineers or a resource for engineers with experience.

This document is entrusted to the recipient personally, but the copyright remains with us. It must not be copied, reproduced or in any way communicated or made accessible to third parties without our written consent.

KLM Technology Group Practical Engineering Guidelines for Processing Plant Solutions	SECTION : INSTRUMENTATION (ENGINEERING DESIGN GUIDELINE)	Page 6 of 58
		Rev: 03
		November 2010

INTRODUCTION

Scope

Instrumentation term is commonly used in engineering, which means measurement and control for industrial process systems. Various processes in petrochemical industries need to be maintained at controlled levels to get the desired product. It is commonly done by controlling such process variables as pressure, temperature, and liquid level; using measurement devices (instrument) with typical control systems. Control instrumentation plays a significant role in both gathering information from the field and changing the field parameters.

This design guideline is covered the selection of measurement devices control system which are commonly used in industries. Measurement device could be classified into various type based on their function. In this guideline, three types of commonly used measurement device are explained in detail; such as pressure, level, and temperature measurement device. Some devices; such as signal transmitter, recorder, and indicator, are generally also networked together to support the measurement device. Those supporting equipments are also explained as well in this guideline. Selection of measurement device mostly based on necessity; which variables need to be controlled. But their accuracy, installation cost, and maintenance also have to be considered as well. Comparing several measurement devices might be important to get the most suitable one.

Besides deciding the measurement device to be used in a process, it is also important to put them in a right order. Hence, the control system and control mode explanation are also included in this guideline. Control system decides how to cope the disturbances in process system by managing behavior of other devices in a system. Generally, controller could be classified into several types based on their characteristic. Each type of controller has their own disadvantages; hence they are commonly combined in industrial process system. It is no way to find the most suitable control system and controller to all petrochemical industrial applications. This guideline gives the basic information as approximation to be applied in industries.

Some sample calculations based on the real industrial samples are also included in this guideline. Calculation spreadsheet for manometer, level measurement using pressure gauge devices and Bimetal thermometers are attached as well and to aid user more understand how to apply the theory for calculations.

These design guideline are believed to be as accurate as possible, but are very general and not for specific design cases. They were designed for engineers to do preliminary designs and process specification sheets. The final design must always be guaranteed for the service selected by the manufacturing vendor, but these guidelines will greatly reduce the amount of up front engineering hours that are required to develop the final design. The guidelines are a training tool for young engineers or a resource for engineers with experience.

This document is entrusted to the recipient personally, but the copyright remains with us. It must not be copied, reproduced or in any way communicated or made accessible to third parties without our written consent.

KLM Technology Group Practical Engineering Guidelines for Processing Plant Solutions	SECTION :	Page 7 of 58
	INSTRUMENTATION (ENGINEERING DESIGN GUIDELINE)	Rev: 03
		November 2010

General Concept of Instrumentation

An instrument is a device that transforms a physical variable (temperature, length, pressure, velocity, capacity, etc) of interest (the measurand) into a form that is suitable for recording (the measurement). In order for the measurement to have broad and consistent meaning, it is common to employ a standard system of units by which the measurement from one instrument can be compared with the measurement of another. An example of a basic instrument is a ruler. In this case the measurand is the length of some object and the measurement is the number of units (meters, inches, etc.) that represent the length. ⁽⁴⁾

Simple instrument model (Figure 1), physical measurement variable is measure by measurand as input to sensor; sensor has a function to convert the input to signal variable; signal variables have the property that they can be manipulated in a transmission system, the signal is transmitted to a display or recording device where the measurement can be read by a human observer.

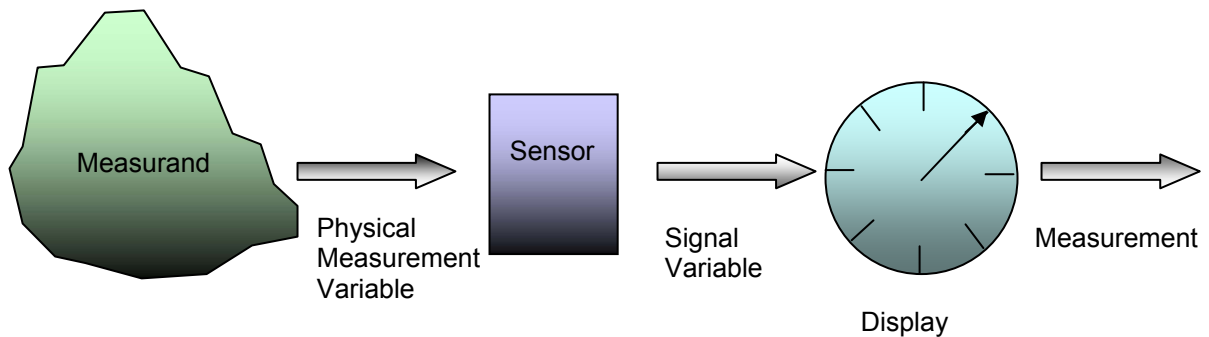

Figure 1: Simple Instrument Model

Instruments used are important for control of process variable (temperature, pressure, level, flow and etc). Objectives of process control are to achieve the safe production, lowest cost of process, improving product quality, lowering labor costs, reducing or eliminating human error, reducing energy consumption, elimination of product giveaway, and products off-spec.

Instrumentation for today industrial normally are equipped with a digital control system (DCS) that provides advanced control capabilities and interfaces to other systems, including management information and accounting systems and read-only interface to protective systems.

These design guideline are believed to be as accurate as possible, but are very general and not for specific design cases. They were designed for engineers to do preliminary designs and process specification sheets. The final design must always be guaranteed for the service selected by the manufacturing vendor, but these guidelines will greatly reduce the amount of up front engineering hours that are required to develop the final design. The guidelines are a training tool for young engineers or a resource for engineers with experience.

This document is entrusted to the recipient personally, but the copyright remains with us. It must not be copied, reproduced or in any way communicated or made accessible to third parties without our written consent.

KLM Technology Group Practical Engineering Guidelines for Processing Plant Solutions	SECTION : INSTRUMENTATION (ENGINEERING DESIGN GUIDELINE)	Page 8 of 58
		Rev: 03
		November 2010

Function of the process control can be class into basic functions and corollary functions. Generally basic functions are needed for plant operability and corollary functions come after plant operability is established.

Basic functions consist of maintaining stability of operating conditions at key points in the process and providing the operator with information of suitable operating condition and the means for adjusting them.

Mean while corollary functions are automating operations which to reduce the demand for continuous operator attention as dictated by economics; insuring that operations are safe for personnel and equipment to met all regulatory requirements; and maintaining product quality while minimizing operating costs.

Instrumentation is usually comprised of a system of pneumatic or electronic devices for measurement and control of all the process variables. Both type of the pneumatic or electronic instrumentation have advantages and disadvantages.

Generally advantage of pneumatic system is intrinsically safe (no electrical circuits), compatible with valves, reliable during power outage for short period of time; and disadvantage are subject to air contaminants, air leaks, mechanical part may fail due to dirt or water, subject to freezing with moisture present and control speed is limited to velocity of sound.

Advantage of electronic system are greater accuracy, more compatible with computer, fast signal transit time, no signal integrity loss if current loop is used; and disadvantage are contacts subject to corrosion, must be air purged, explosion proof, or intrinsically safe to be used in hazardous areas, subject to electrical interference, and more difficult to provide for positive fail-safe operation.

Pneumatic Power Supplies

Usually know also know as instrument air system, main consideration of the system are

- i) Adequate Capacity of the air supply to all instruments in the system. Normally the capacity should maintain at sum of the individual requirements of each instrument requirement in the system plus supplemental volume for purges, leaks, additions and etc. It estimated consumption volume of volume of 3.7 US

These design guideline are believed to be as accurate as possible, but are very general and not for specific design cases. They were designed for engineers to do preliminary designs and process specification sheets. The final design must always be guaranteed for the service selected by the manufacturing vendor, but these guidelines will greatly reduce the amount of up front engineering hours that are required to develop the final design. The guidelines are a training tool for young engineers or a resource for engineers with experience.

This document is entrusted to the recipient personally, but the copyright remains with us. It must not be copied, reproduced or in any way communicated or made accessible to third parties without our written consent.

KLM Technology Group Practical Engineering Guidelines for Processing Plant Solutions	SECTION : INSTRUMENTATION (ENGINEERING DESIGN GUIDELINE)	Page 9 of 58
		Rev: 03
		November 2010

gallons per minute for each air-consuming device is usually adequate. The air storage tank should have sufficient capacity to maintain that flow rate for five minutes or more as is considered adequate to perform an emergency shut-down of plant.

- ii) Filtering is required for instrument air since the contamination such as oil, water, and any hazardous or corrosive gases is not allowed. Non-lubricated compressors should be used if possible, because presence of oil in compressors system may cause air contamination and may create a combustible mixture. After the compressing process instrument air will be cooled to remove the contained water. A drying system must be installed to maintain the water dew point at least 42.8 ° F (6°C) below the ambient temperature at line pressure. An after filter is required to remove particulate carryover from the dehydrators.
- iii) Safety Regulation is practiced since the instrument air system is designed for high pressure (up to 59.5 psig) this means relief valve should be installed to protect the system.
- iv) The air distribution system should be free of any “pocket” which liquid could accumulate. If the “pocket” could not be eliminated drain valve should be installed.

Important of Instrumentation Control for Unit Operation

When establish control system for a unit operation (reactor, fractionators, and fire heaters) is very important to ensure that control of each equipment item and circuit provides the ability to maintain material balance, maintain heat balance and allow control of product quality to the necessary degree.

Material balance control is to control to prevent build-up or depletion of material for continuous processes. Material balance is easily obtained in piping circuits system, since there is no place in which to store material and no storage from which to withdraw it.

In the feed circuit as in fractionation tower, material balance is obtained without automatic control. This is because whatever material is pumped into the circuit exits into the tower and the separately pressure-controlled tower acts as a pressure sink for the feed circuit. For situations in which the circuit pressure must be held higher than would be required merely because of pipe friction pressure drop, material balance is maintained through the use of a pressure controller and valve. With this arrangement, pressure is used as a

These design guideline are believed to be as accurate as possible, but are very general and not for specific design cases. They were designed for engineers to do preliminary designs and process specification sheets. The final design must always be guaranteed for the service selected by the manufacturing vendor, but these guidelines will greatly reduce the amount of up front engineering hours that are required to develop the final design. The guidelines are a training tool for young engineers or a resource for engineers with experience.

This document is entrusted to the recipient personally, but the copyright remains with us. It must not be copied, reproduced or in any way communicated or made accessible to third parties without our written consent.

KLM Technology Group Practical Engineering Guidelines for Processing Plant Solutions	SECTION : INSTRUMENTATION (ENGINEERING DESIGN GUIDELINE)	Page 10 of 58
		Rev: 03
		November 2010

measure of material balance. Controlling the balance of material may be more difficult when variable holdup of material is possible. In these situations, a level measurement monitors buildup or depletion of liquid and is therefore the basis for control of material balance. Buildup or depletion of vapor in a tower is commonly based on pressure measurement, with many possibilities for valve location. Material balance are achieved when the pressure and bottom level are maintained in the tower.

Heat balance control is achieved when the temperature in the unit operation is maintained. In contrast to material balance, heat balance in piping circuits can become quite complex. Heat balance in the fractionation tower can be achieved by maintain of bottom temperature in towers with control the heat supply (normally steam flow rate) from boiler. In this cascade control of heat balance, the success only can be achieve when level in the bottom tower is maintain, that mean material balance is achieved.

By maintaining material and heat balance in the circuits or unit operation, the product quality control can be achieved and maintaining. That mean stability of operating conditions at key points in the process is the success of the product quality control. The measurement of product quality is made either directly (i.e., continuously with an on-line analyzer) or indirectly (i.e., by means of a correlation). The end point of the overhead liquid product from the tower is an example. This end point may be measured directly with a boiling point device, or it may be inferred from a vapor line temperature. The essential point is that when laying out a control system, the basic measurement information and means for making an adjustment must be made available to the operator.

Process Variable Measurement Instrument

Process variable such as pressure, level, temperature, flow rate and etc, can be measure with the specific measurement instrument and control with specific control valve / control system.

Pressure measurement instrument in today market can be classified as manometer, Bourdon tubes, Bellows, diaphragm and electrical pressure transducers.

Level measurement instrument use in today industrial can be classified as gauge glass, chain and tape float gauges, lever and shaft float gauges, displacer level measuring device, head-pressure level gauges, electrical type level gauges and magnetic gauge.

These design guideline are believed to be as accurate as possible, but are very general and not for specific design cases. They were designed for engineers to do preliminary designs and process specification sheets. The final design must always be guaranteed for the service selected by the manufacturing vendor, but these guidelines will greatly reduce the amount of up front engineering hours that are required to develop the final design. The guidelines are a training tool for young engineers or a resource for engineers with experience.

This document is entrusted to the recipient personally, but the copyright remains with us. It must not be copied, reproduced or in any way communicated or made accessible to third parties without our written consent.

KLM Technology Group Practical Engineering Guidelines for Processing Plant Solutions	SECTION : INSTRUMENTATION (ENGINEERING DESIGN GUIDELINE)	Page 11 of 58
		Rev: 03
		November 2010

Temperature measurement instrument can be classified into thermocouples, resistance thermometers (RTD), and bimetallic thermometers.

The flow rate measurement instrument can be referring to “Flow Measurement Selection and Sizing Engineering Design Guideline” and for the Control valve instrumentation can be referring to “Control Valve Selection and Sizing Engineering Design Guidelines”. Both guidelines have discussed in detail of the respective instrumentation selection and included sizing as well.

Each type of the difference process variable measurement instrument have difference design and suitable for differences process. That means the knowledge of the selection is very important of the suitable measurement instrument for the specific process and will be discussed in later section.

These design guideline are believed to be as accurate as possible, but are very general and not for specific design cases. They were designed for engineers to do preliminary designs and process specification sheets. The final design must always be guaranteed for the service selected by the manufacturing vendor, but these guidelines will greatly reduce the amount of up front engineering hours that are required to develop the final design. The guidelines are a training tool for young engineers or a resource for engineers with experience.

This document is entrusted to the recipient personally, but the copyright remains with us. It must not be copied, reproduced or in any way communicated or made accessible to third parties without our written consent.

KLM Technology Group Practical Engineering Guidelines for Processing Plant Solutions	SECTION : INSTRUMENTATION (ENGINEERING DESIGN GUIDELINE)	Page 12 of 58
		Rev: 03
		November 2010

DEFINITION

Amplifier- A device which draws power from a source other than the input signal and which produces as an output an enlarged reproduction of the essential features of its input.

Adaptive Control - Method of control whereby tuning (response) of the control system is varied with the process condition, unlike other control where tuning is manual and remains constant.

Bourdon Tube – It uses a coiled tube which as it expands due to pressure increase causes a rotation of an arm connected to the tube.

Capacity - Is the water handling capability of a pump commonly expressed as either gallon per minute (gal/min) or cubic meter per minute (m³/min).

Cascade Control – Controllers arranged such that the output of one controller manipulates the set point input of a second controller instead of manipulating a process variable directly.

Control Action, Derivatives (Rate)- Control action with the controller output proportional to the rate of change of the input.

Control Action Integral (Reset) – Control action with the controller output proportional to the time integral of the error signal.

Control Action, Proportional – Control action with the controller output has a linear relationship to the error signal.

Controller - A device which receives a measurement of the process variable, compares that measurement with a set point representing the desired control point, and adjusts its output based on the selected control algorithm to minimize the error between the measurement and the set point. If an increase in the measured process variable above the set point causes an increase in the magnitude of the controller output, the controller is said to be “direct acting”. If a process variable increase above the set point causes a decrease in the magnitude of the controller output, the controller is “reverse acting”.

Displacer – Is a level measurement devices, displacer density will be greater than the liquid and will act as an immersed body. Operation of the displacer is based on the

These design guideline are believed to be as accurate as possible, but are very general and not for specific design cases. They were designed for engineers to do preliminary designs and process specification sheets. The final design must always be guaranteed for the service selected by the manufacturing vendor, but these guidelines will greatly reduce the amount of up front engineering hours that are required to develop the final design. The guidelines are a training tool for young engineers or a resource for engineers with experience.

This document is entrusted to the recipient personally, but the copyright remains with us. It must not be copied, reproduced or in any way communicated or made accessible to third parties without our written consent.

KLM Technology Group Practical Engineering Guidelines for Processing Plant Solutions	SECTION : INSTRUMENTATION (ENGINEERING DESIGN GUIDELINE)	Page 13 of 58
		Rev: 03
		November 2010

measurement of the change in buoyancy of the displacer as the level changes over its length.

Distribution Control System (DCS) – Is a system consists of some number of microprocessor-based nodes that are interconnected by a digital communications network, often called a data highway. It is type of computer process control system.

Manometer – Is a device to measure pressures. A common simple manometer consists of a *U* shaped tube of glass filled with some liquid. Typically the liquid is mercury because of its high density.

PD Controller- A controller with proportional plus derivatives (rate) control action.

PI Controller – A controller with proportional plus integral (reset) control action.

PID Controller – A controller with proportional plus integral plus derivative control action.

RTD (Resistance Temperature Detector) - A resistance temperature detector operates on the principle of the change in electrical resistance in wire as a function of temperature.

RTD Element -Sensing portion of the RTD which can be made most commonly of platinum, nickel, or copper.

Set Point – The desired value at which a process variable is to be controlled.

Transmitter – A device that converts a process measurement variable into an electrical or pneumatic signal suitable for use by an indicating or control system.

Thermocouple Thermometer – Is a temperature measuring system comprising a temperature sensing element called a *thermocouple* which produces an electromotive force (emf), a device for sensing emf which includes a printed scale for converting -emf to equivalent temperature units, and *electrical conductors* for operatively connecting the two.

Thermistor Thermometer - Is a special type of resistor 'comprised of a mixture of metallic oxides known as semiconductors which are substances whose electrical conductivity at or near room temperature is less than that of metals but greater than that of typical insulators, Semiconductors have a high negative temperature coefficient in contrast with most metals which have a positive coefficient.

These design guideline are believed to be as accurate as possible, but are very general and not for specific design cases. They were designed for engineers to do preliminary designs and process specification sheets. The final design must always be guaranteed for the service selected by the manufacturing vendor, but these guidelines will greatly reduce the amount of up front engineering hours that are required to develop the final design. The guidelines are a training tool for young engineers or a resource for engineers with experience.

This document is entrusted to the recipient personally, but the copyright remains with us. It must not be copied, reproduced or in any way communicated or made accessible to third parties without our written consent.

KLM Technology Group Practical Engineering Guidelines for Processing Plant Solutions	SECTION : INSTRUMENTATION (ENGINEERING DESIGN GUIDELINE)	Page 14 of 58
		Rev: 03
		November 2010

NOMENCLATURE

A	Cross section area of body displacer, ft ²
b	Length of displacer body, ft
C	Controlled Variable
c	Output bias or Manual reset
d	Thickness of flat strip, mm
E	Error = PV –SP
F _B	Buoyant force, lbm.ft/s ²
F _G	Weight force, lbm.ft/s ²
F _R	Net force F _B –F _G , lbm.ft/s ²
f	Movement of flat strip, mm
g	Acceleration of gravity, SI unit or 32.2 ft/s ²
Δh	Difference height of the liquid level in manometer, SI unit
k	Specific bending coefficient, 1/°C
K _i	Integral mode gain constant
K _p	Proportional gain, (pure number)
L	Fluid level in tank, ft
L _d	Dipped length, ft
ℓ	Height distance between points of measure P ₁ and P ₂ , ft
ℓ	Length of flat strip, mm
m	Mass of the displacer body immersed in liquid, lbm
P	Absolute pressure, SI unit or Hydrostatic pressure at bottom tank, psig
P ₁	Absolute pressure at location 1 in tank, psig
P ₂	Absolute pressure at location 2 in tank, psig
P ₀	Atmospheric pressure, psia
P _{ref}	Absolute pressure reference, SI unit
PB	Proportional band in percent, %
SP	Set – Point
T _i	Integral mode time constant
ΔT	Temperature change, °C
K _d	Derivative mode gain constant
T _d	Derivative mode time constant

These design guideline are believed to be as accurate as possible, but are very general and not for specific design cases. They were designed for engineers to do preliminary designs and process specification sheets. The final design must always be guaranteed for the service selected by the manufacturing vendor, but these guidelines will greatly reduce the amount of up front engineering hours that are required to develop the final design. The guidelines are a training tool for young engineers or a resource for engineers with experience.

This document is entrusted to the recipient personally, but the copyright remains with us. It must not be copied, reproduced or in any way communicated or made accessible to third parties without our written consent.

KLM Technology Group Practical Engineering Guidelines for Processing Plant Solutions	SECTION : INSTRUMENTATION (ENGINEERING DESIGN GUIDELINE)	Page 15 of 58
		Rev: 03
		November 2010

Greek letters

ρ_A	Density of gas or atmospheric, lbm/ft ³
ρ_B	Weight density of fluid in manometer, SI unit
ρ_D	Density of the displacer, lbm/ft ³
ρ_L	Density of liquid, lbm/ft ³
θ	Angle of column relative the horizontal plane
μ	Absolute (dynamic) viscosity, cp
v_1	Velocity for upstream, ft/s
v_2	Velocity for downstream, ft/s

These design guideline are believed to be as accurate as possible, but are very general and not for specific design cases. They were designed for engineers to do preliminary designs and process specification sheets. The final design must always be guaranteed for the service selected by the manufacturing vendor, but these guidelines will greatly reduce the amount of up front engineering hours that are required to develop the final design. The guidelines are a training tool for young engineers or a resource for engineers with experience.

This document is entrusted to the recipient personally, but the copyright remains with us. It must not be copied, reproduced or in any way communicated or made accessible to third parties without our written consent.

KLM Technology Group Practical Engineering Guidelines for Processing Plant Solutions	SECTION : INSTRUMENTATION (ENGINEERING DESIGN GUIDELINE)	Page 16 of 58
		Rev: 03
		November 2010

THEORY

A) Pressure Measurement

Pressure defined as force per unit area exerted by a fluid (liquid or gas) on any surface. Usually is expressed in terms of units of weight-force and area (lb/ft^2) or the height of a column of liquid (ft) that produces a like pressure at its base.

Absolute pressure (P_{absolute}) is the pressure difference between the point of measurement and a perfect vacuum where pressure is zero ($P_{\text{absolute}} = P_{\text{gauge}} + P_{\text{atm}}$). Gauge pressure (P_{gauge}) is the pressure difference between the point of measurement and the ambient. In reality, the atmospheric pressure (P_{atm}) can vary, but only the pressure difference is of interest in gauge pressure measurements.

The most direct way of measuring pressure is to isolate an area on an elastic mechanical element for the force to act on. The deformation of the sensing element produces displacements and strains that can be precisely sensed to give a calibrated measurement of the pressure. This is the basis method of measurement of pressure for all commercially available pressure sensors today.

Process pressure measuring devices may be divided into three groups: (1) based on the measurement of the height of a liquid column, (2) based on the measurement of the distortion of an elastic pressure chamber, and (3) electrical sensing devices.

Height of a Liquid Column

Manometers common consists of a *U* shaped tube of glass filled with some liquid (either water or mercury). Typically the liquid is mercury because of its high density. Manometers measurement methods are based on the measurement of the height of liquid-column, which the pressure being measured is balanced against the pressure exerted by a column of liquid. If the density of the liquid is known, the height of the liquid column is a measure of the pressure.

The height of the liquid column may be measured in length units or be calibrated in pressure units. Depending on the pressure range, water and mercury are the liquids most frequently used for manometer. Since the density of the liquid used varies with temperature, the temperature must be taken into account for accurate pressure measurements.

These design guideline are believed to be as accurate as possible, but are very general and not for specific design cases. They were designed for engineers to do preliminary designs and process specification sheets. The final design must always be guaranteed for the service selected by the manufacturing vendor, but these guidelines will greatly reduce the amount of up front engineering hours that are required to develop the final design. The guidelines are a training tool for young engineers or a resource for engineers with experience.

This document is entrusted to the recipient personally, but the copyright remains with us. It must not be copied, reproduced or in any way communicated or made accessible to third parties without our written consent.

KLM Technology Group Practical Engineering Guidelines for Processing Plant Solutions	SECTION : INSTRUMENTATION (ENGINEERING DESIGN GUIDELINE)	Page 17 of 58
		Rev: 03
		November 2010

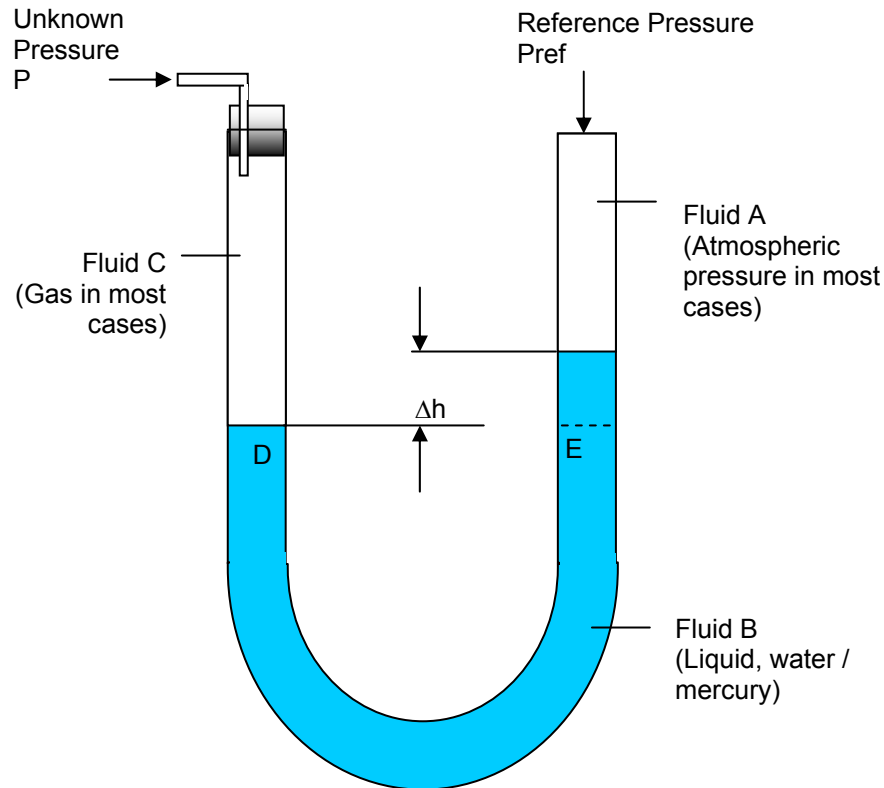

Figure 2: U- Shape Tube Manometer

The difference of the level of the liquid on both sides of the U tube, the unknown pressure P for gas fluid C can be determine with fluid statics formula as below,

$$P = P_{ref} + \rho_B g \Delta h \quad \text{Eq (1)}$$

The gauge pressure of P can be determinate with

$$P_{gauge} = P - P_{ref} = \rho_B g \Delta h \quad \text{Eq (2)}$$

These design guideline are believed to be as accurate as possible, but are very general and not for specific design cases. They were designed for engineers to do preliminary designs and process specification sheets. The final design must always be guaranteed for the service selected by the manufacturing vendor, but these guidelines will greatly reduce the amount of up front engineering hours that are required to develop the final design. The guidelines are a training tool for young engineers or a resource for engineers with experience.

This document is entrusted to the recipient personally, but the copyright remains with us. It must not be copied, reproduced or in any way communicated or made accessible to third parties without our written consent.

KLM Technology Group Practical Engineering Guidelines for Processing Plant Solutions	SECTION : INSTRUMENTATION (ENGINEERING DESIGN GUIDELINE)	Page 18 of 58
		Rev: 03
		November 2010

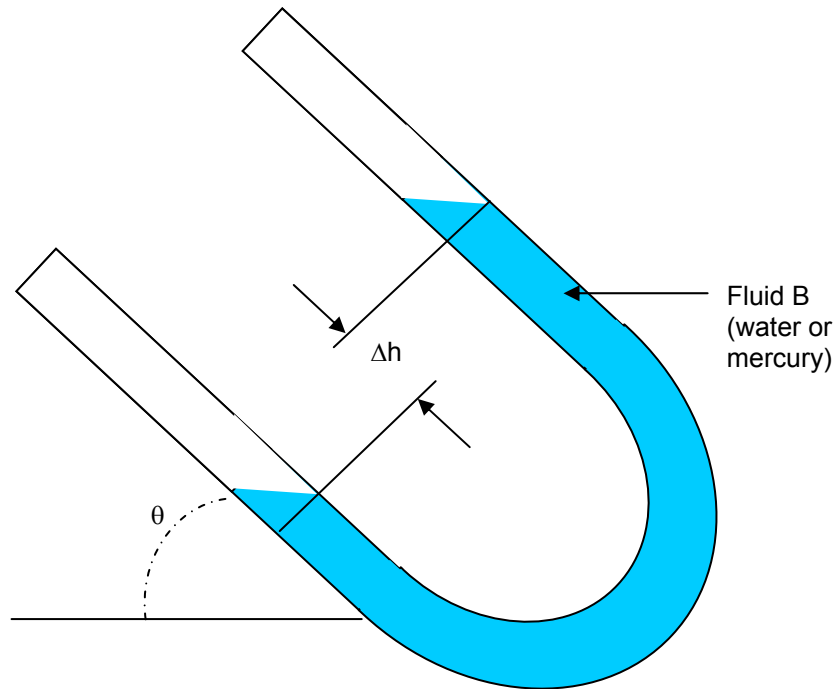

Figure 3: Inclined U-Tube Manometer

The pressure difference in a inclined u-tube can be expressed as

$$\Delta P = \rho_B g h \sin(\theta) \quad \text{Eq (3)}$$

where

θ = angle of column relative the horizontal plane

Elastic-Element – Bourdon Tube, Bellows and Diaphragm

These measuring devices are base on method which the measured pressure deforms some elastic material (metallic) within its elastic limit, the magnitude of the deformation being approximately proportional to the applied pressure.

These design guideline are believed to be as accurate as possible, but are very general and not for specific design cases. They were designed for engineers to do preliminary designs and process specification sheets. The final design must always be guaranteed for the service selected by the manufacturing vendor, but these guidelines will greatly reduce the amount of up front engineering hours that are required to develop the final design. The guidelines are a training tool for young engineers or a resource for engineers with experience.

This document is entrusted to the recipient personally, but the copyright remains with us. It must not be copied, reproduced or in any way communicated or made accessible to third parties without our written consent.

KLM Technology Group Practical Engineering Guidelines for Processing Plant Solutions	SECTION : INSTRUMENTATION (ENGINEERING DESIGN GUIDELINE)	Page 19 of 58
		Rev: 03
		November 2010

i) Bourdon Tubes

A Bourdon tube was discovered in year 1849 in France by Eugene Bourdon. It is the most widely used instruments for measuring the pressure of liquids and gases and measure up to pressures of 100,000 pounds per square inch. Bourdon tubes general are designed used for measuring high pressures application.

Structure of Bourdon tube is form of tube which is curved or twisted along its length and has an oval cross-section. The tube is sealed at one end and tends to unwind or straighten when it is subjected to a pressure applied to the inside.

The most frequently used process pressure-indicating device is the C-spring Bourdon-tube pressure gauge. General types are available in a wide variety of pressure ranges and materials of construction. Materials of construction are selected base on the basis pressure range, resistance to corrosion by the process materials, and effect of temperature on calibration.

A typical C-spring Bourdon tube contains a curved tube that is open to external pressure input on one end and is coupled mechanically to an indicating needle on the other end, Figure 4. The external pressure is guided into the tube and causes it to flex, resulting in a change in curvature of the tube. These curvature changes are linked to the dial indicator for a number readout.

These design guideline are believed to be as accurate as possible, but are very general and not for specific design cases. They were designed for engineers to do preliminary designs and process specification sheets. The final design must always be guaranteed for the service selected by the manufacturing vendor, but these guidelines will greatly reduce the amount of up front engineering hours that are required to develop the final design. The guidelines are a training tool for young engineers or a resource for engineers with experience.

This document is entrusted to the recipient personally, but the copyright remains with us. It must not be copied, reproduced or in any way communicated or made accessible to third parties without our written consent.

KLM Technology Group Practical Engineering Guidelines for Processing Plant Solutions	SECTION : INSTRUMENTATION (ENGINEERING DESIGN GUIDELINE)	Page 20 of 58
		Rev: 03
		November 2010

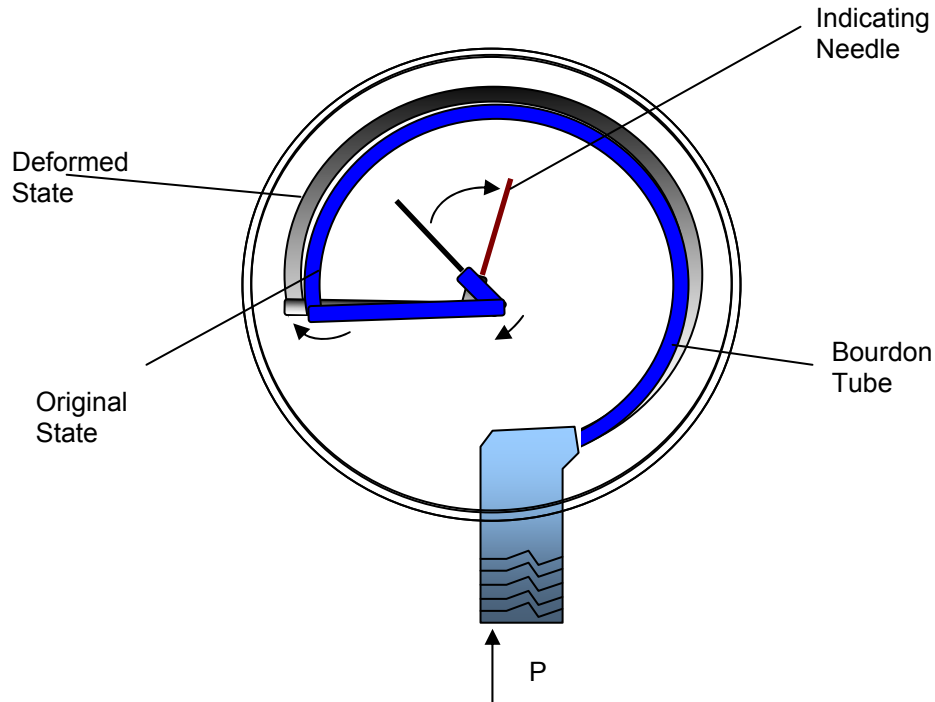

Figure 4: C-spring Bourdon-Tube Pressure Gauge

ii) Bellows

The bellows element is an axially elastic cylinder with deep folds or convolutions. Types of bellows may classify as unopposed, spring-loaded and beam balance sensor. The pressure to be measured may be applied either to the inside or to the space outside the bellows, with the other side exposed to atmospheric pressure. For measurement of absolute pressure either the inside or the space outside of the bellows can be evacuated and sealed. Differential pressures may be measured by applying the pressures to opposite sides of a single bellows or to two opposing bellows.

Bellows is usually for measuring low pressures or vacuum services, but types are available for use with high pressures as well. Typical diameters of bellow are range from 10 to 300 mm. As per Bourdon tube, it indicates pressures as gauge or relative to its surroundings.

These design guideline are believed to be as accurate as possible, but are very general and not for specific design cases. They were designed for engineers to do preliminary designs and process specification sheets. The final design must always be guaranteed for the service selected by the manufacturing vendor, but these guidelines will greatly reduce the amount of up front engineering hours that are required to develop the final design. The guidelines are a training tool for young engineers or a resource for engineers with experience.

This document is entrusted to the recipient personally, but the copyright remains with us. It must not be copied, reproduced or in any way communicated or made accessible to third parties without our written consent.

KLM Technology Group Practical Engineering Guidelines for Processing Plant Solutions	SECTION : INSTRUMENTATION (ENGINEERING DESIGN GUIDELINE)	Page 21 of 58
		Rev: 03
		November 2010

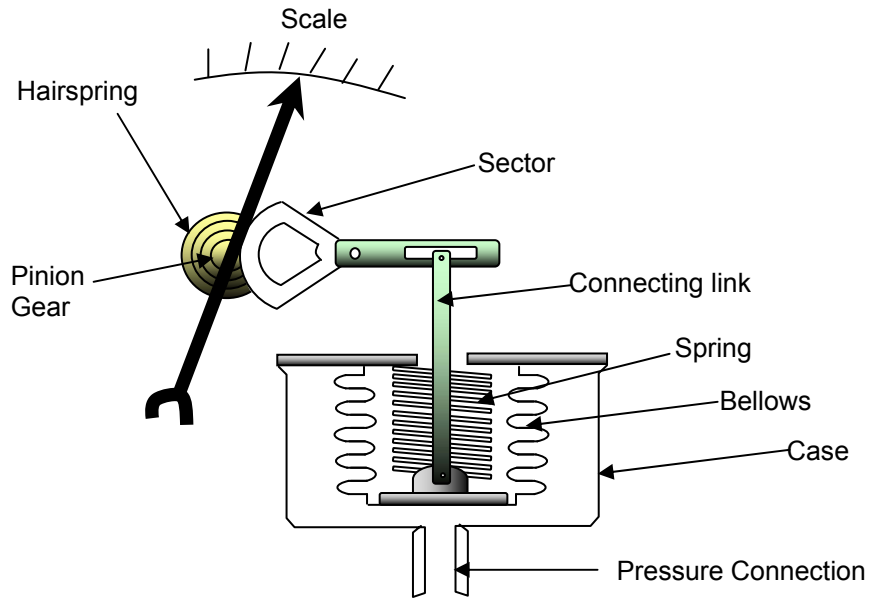

Figure 5: Spring-Loaded Bellows

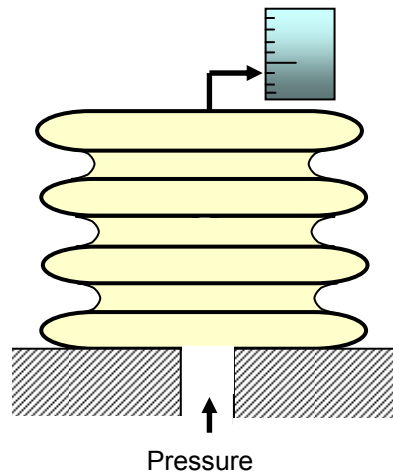

Figure 6: Unopposed Bellows

These design guideline are believed to be as accurate as possible, but are very general and not for specific design cases. They were designed for engineers to do preliminary designs and process specification sheets. The final design must always be guaranteed for the service selected by the manufacturing vendor, but these guidelines will greatly reduce the amount of up front engineering hours that are required to develop the final design. The guidelines are a training tool for young engineers or a resource for engineers with experience.

This document is entrusted to the recipient personally, but the copyright remains with us. It must not be copied, reproduced or in any way communicated or made accessible to third parties without our written consent.

KLM Technology Group Practical Engineering Guidelines for Processing Plant Solutions	SECTION : INSTRUMENTATION (ENGINEERING DESIGN GUIDELINE)	Page 22 of 58
		Rev: 03
		November 2010

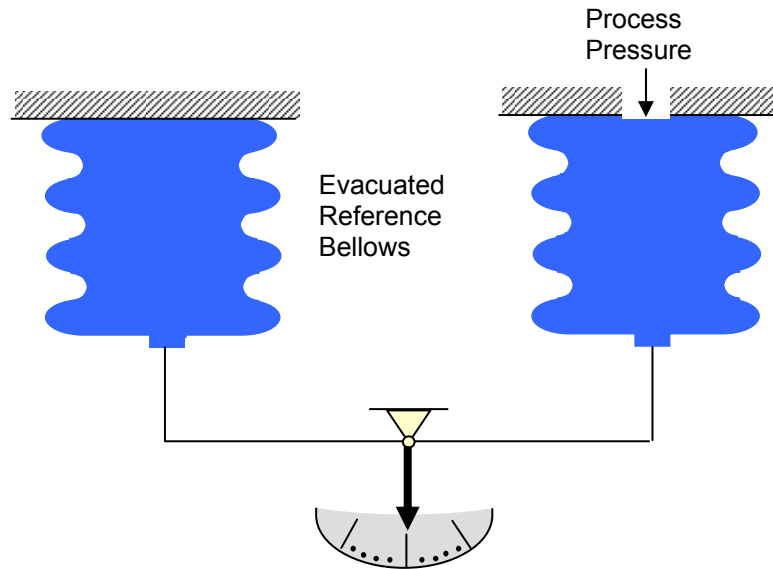

Figure 7: Beam Balance Sensor Bellows

iii) Diaphragms

Diaphragms are by far the most widely used of all sensing elements. It may be classified into two types: with utilize the elastic characteristics of the diaphragm and diaphragms which are opposed by a spring or other separate elastic element.

The first type usually consists of one or more capsules, each composed of two diaphragms bonded together by soldering, or welding. The diaphragms are flat or corrugated circular metallic disks. Diaphragm elements used included brass, phosphor bronze, beryllium copper, and stainless steel. It pressure determined by the amount of deflection of a flexible membrane, by referring to known pressures deflection is repeatable. The deformation of a thin diaphragm is dependent on the difference in pressure between its two faces. The reference face can be open to atmosphere to measure gauge pressure, open to a second port to measure differential pressure, or can be sealed against a vacuum or other fixed reference pressure to measure absolute pressure. It can measure pressure from fractions of an inch of water to about 206.8kPa gauge.

These design guideline are believed to be as accurate as possible, but are very general and not for specific design cases. They were designed for engineers to do preliminary designs and process specification sheets. The final design must always be guaranteed for the service selected by the manufacturing vendor, but these guidelines will greatly reduce the amount of up front engineering hours that are required to develop the final design. The guidelines are a training tool for young engineers or a resource for engineers with experience.

This document is entrusted to the recipient personally, but the copyright remains with us. It must not be copied, reproduced or in any way communicated or made accessible to third parties without our written consent.

KLM Technology Group Practical Engineering Guidelines for Processing Plant Solutions	SECTION :	Page 23 of 58
	INSTRUMENTATION	Rev: 03
	(ENGINEERING DESIGN GUIDELINE)	November 2010

The second type of diaphragm is used for containing the pressure and exerting a force on the opposing elastic element. The diaphragm is a flexible or slack diaphragm of rubber, leather, impregnated fabric, or plastic. Movement of the diaphragm is opposed by a spring that determines the deflection for a given pressure. This type of diaphragm is used for the measurement of extremely low pressure, vacuum, or differential pressure.

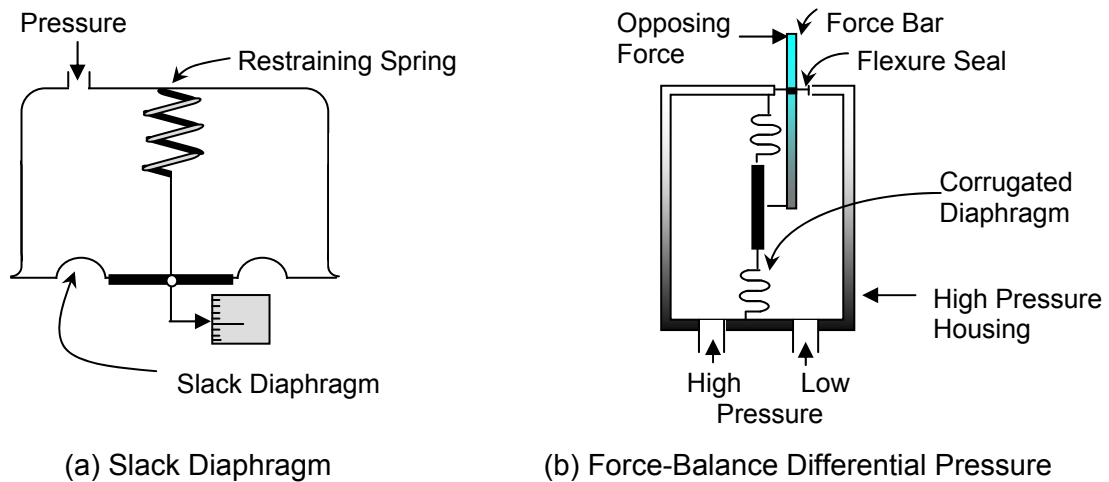

Figure 8: Diaphragm Pressure Elements

Electrical Method -Electrical Pressure Transducers

Generally the sensing element of the electrical pressure transducers are takes the form of Bourdon tube, bellows, or diaphragm to generate a movement and transmitted to a strain gauge or others electrical pressure transducers use properties of inductance, capacitance, or magnetic coupling to convert a pressure measurement to an electrical signal.

i) Strain Gauges

When a wire is stretched elastically, its length is increased and its diameter is decreased. Both of these dimensional changes result in an increase in the electrical resistance of the conductor. Devices utilizing resistance wire grids for measuring small distortions in elastically stressed materials are commonly called strain gauges. The strain gauges are usually connected electrically in a Wheatstone-bridge configuration to generate an

These design guideline are believed to be as accurate as possible, but are very general and not for specific design cases. They were designed for engineers to do preliminary designs and process specification sheets. The final design must always be guaranteed for the service selected by the manufacturing vendor, but these guidelines will greatly reduce the amount of up front engineering hours that are required to develop the final design. The guidelines are a training tool for young engineers or a resource for engineers with experience.

This document is entrusted to the recipient personally, but the copyright remains with us. It must not be copied, reproduced or in any way communicated or made accessible to third parties without our written consent.

KLM Technology Group Practical Engineering Guidelines for Processing Plant Solutions	SECTION : INSTRUMENTATION (ENGINEERING DESIGN GUIDELINE)	Page 24 of 58
		Rev: 03
		November 2010

electrical signal proportional to the movement and hence proportional to the process variable (pressure) being measured.

There are two forms of strain-gauge: bonded and un-bonded. Bonded strain gauges are bonded directly to the surface of the elastic element whose strain is to be measured. The un-bonded-strain-gauge transducer consists of a fixed frame and an armature which moves with respect to the frame in response to the measured pressure. The strain-gauge wire filaments are stretched between the armature and frame.

Strain-gauge pressure transducers are manufactured for measuring gauge, absolute, and differential pressures and vacuum. Generally the design full-scale ranges from 1.0 in of water to 10,134 MPa are available. ⁽⁶⁾ Strain gauges which bonded directly to a diaphragm pressure-sensitive element usually have an extremely fast response time and are suitable for high-frequency dynamic-pressure measurements.

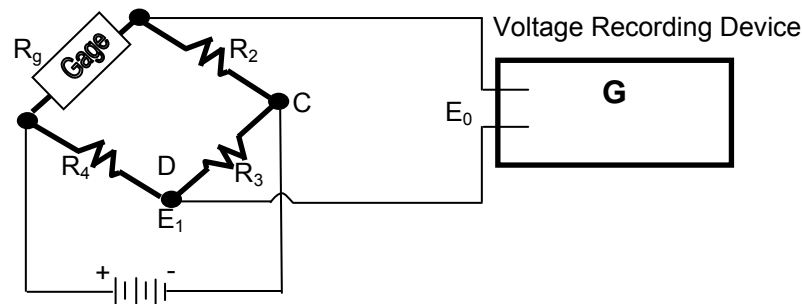

Figure 9: The Wheatstone Bridge

B) Level Measurement

Level is defined as the filling height of a liquid or bulk material, for example, in a tank or reservoir. Generally, the position of the surface is measured relative to a fixed datum plane, usually the tank bottom. If the product's surface is not flat (e.g., with foam, waves, turbulences, or with coarse-grained bulk material) level usually is defined as the average height of a bounded area. Level measurement applications are divided into four areas: liquids, bulk solids, continuous measurement and level limit detection.

These design guideline are believed to be as accurate as possible, but are very general and not for specific design cases. They were designed for engineers to do preliminary designs and process specification sheets. The final design must always be guaranteed for the service selected by the manufacturing vendor, but these guidelines will greatly reduce the amount of up front engineering hours that are required to develop the final design. The guidelines are a training tool for young engineers or a resource for engineers with experience.

This document is entrusted to the recipient personally, but the copyright remains with us. It must not be copied, reproduced or in any way communicated or made accessible to third parties without our written consent.

KLM Technology Group Practical Engineering Guidelines for Processing Plant Solutions	SECTION : INSTRUMENTATION (ENGINEERING DESIGN GUIDELINE)	Page 25 of 58
		Rev: 03
		November 2010

Level limit detection is the essential task to avoid overflowing or excessive emptying of tanks and to protect pumps from running dry. In level limit detection, fast and safe functioning and high reproducibility are of great importance.

Continuous level measurement determines the level of media, it actually measures the length. The measuring ranges cover from a few cm for control tasks, typically 2 to 10 m for liquid applications through to 70 m in bulk solids, e. g. grain silos.

A commonly used basis for classification of level devices is as follows: gauge glass, differential pressure gauge, chain and tape float gauges, lever and shaft float gauges, displacer, head devices, and electrical level gauge. Selections of use of level devices are depending mainly on fluid characteristics.

Gauge Glass

Gauge glass is the most simple and common use visual level measurement device. Generally level tube can be classified as transparent or reflex types.

A transparent tube gauge glass is attached to the bottom and top (top connection not needed in a tank open to atmosphere) of the tank that is monitored, and the height of the liquid in the tube will be equal to the height of liquid in the tank. Since the process fluid level is view directly, the transparent gauge glass is normally used with opaque fluids. Transparent gauge glasses made from tubular glass or plastic can use for service up to 450 psig and 400°F. Some of the designs of transparent and high pressure gauges are suitable for corrosive and high pressure service up to 5000psi. The glass section is usually flat to provide strength and safety.

A reflex tube gauge glass design with one side of the glass section is prism-shaped, which aid in viewing transparent fluids. The glass is one side has 90-degree angles which run lengthwise. Light rays strike the outer surface of the glass at a 90-degree angle. The light rays travel through the glass striking the inner side of the glass at a 45-degree angle. The presence or absence of liquid in the chamber determines if the light rays are refracted into the chamber or reflected back to the outer surface of the glass.

Reflex Level Gauges suitable for storage tanks, low pressure boilers and liquid gases. The prismatic effect in the glass makes the liquid appear black and therefore giving clear indication of level.

These design guideline are believed to be as accurate as possible, but are very general and not for specific design cases. They were designed for engineers to do preliminary designs and process specification sheets. The final design must always be guaranteed for the service selected by the manufacturing vendor, but these guidelines will greatly reduce the amount of up front engineering hours that are required to develop the final design. The guidelines are a training tool for young engineers or a resource for engineers with experience.

This document is entrusted to the recipient personally, but the copyright remains with us. It must not be copied, reproduced or in any way communicated or made accessible to third parties without our written consent.

KLM Technology Group Practical Engineering Guidelines for Processing Plant Solutions	SECTION :	Page 26 of 58
	INSTRUMENTATION	Rev: 03
	(ENGINEERING DESIGN GUIDELINE)	November 2010

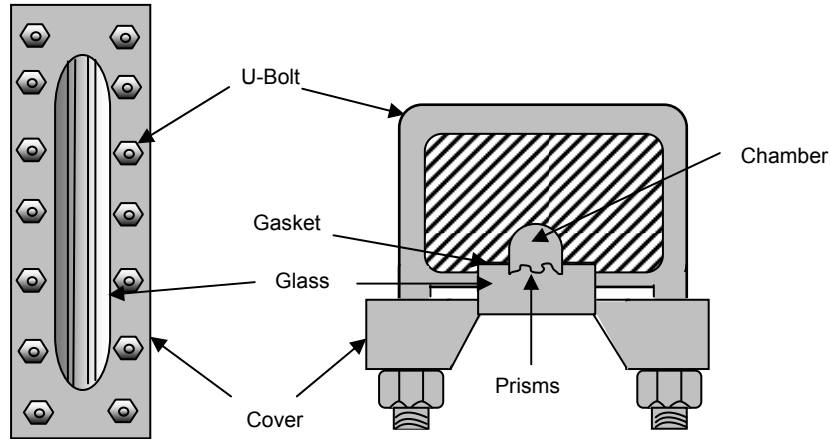

Figure 10: Reflex Gauge Glass

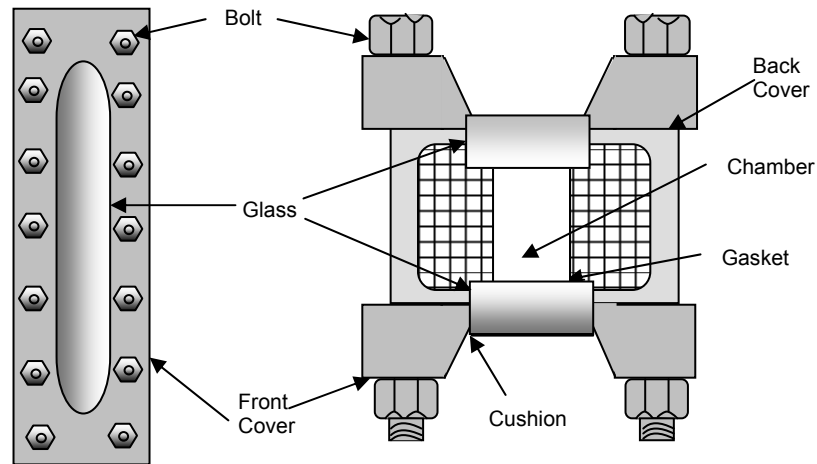

Figure 11: Transparent Gauge Glass

Chain or Tape Float Gauges

Chain or tape float gauge as per Figure 12, the float is connected to the indicating mechanism by means of a flexible chain or tape. Used in large, un-pressurized/atmospheric pressure storage tank where the entire full-to-empty ranges can be measured. The gauge-board type is provided with a counterweight to keep the tape or

These design guideline are believed to be as accurate as possible, but are very general and not for specific design cases. They were designed for engineers to do preliminary designs and process specification sheets. The final design must always be guaranteed for the service selected by the manufacturing vendor, but these guidelines will greatly reduce the amount of up front engineering hours that are required to develop the final design. The guidelines are a training tool for young engineers or a resource for engineers with experience.

This document is entrusted to the recipient personally, but the copyright remains with us. It must not be copied, reproduced or in any way communicated or made accessible to third parties without our written consent.

KLM Technology Group Practical Engineering Guidelines for Processing Plant Solutions	SECTION :	Page 27 of 58
	INSTRUMENTATION	Rev: 03
	(ENGINEERING DESIGN GUIDELINE)	November 2010

chain taut. The tape is stored in the gauge head on a spring-loaded reel. The float is usually a pancake-shaped hollow metal float with guide wires from top to bottom of the tank to constrain it. ⁽⁶⁾ Disadvantage of the float gauge are high maintenance and poor accuracy, and for that reason is being replaced and displaced by less intrusive, lower maintenance devices.

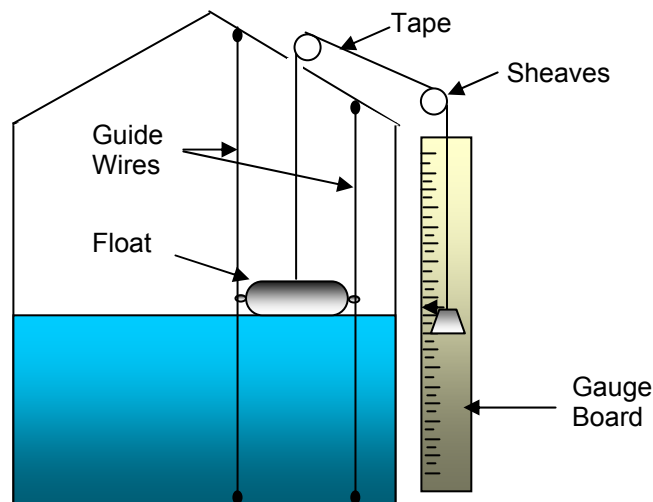

Figure 12: Chain and Tape Float Gauge

Lever and Shaft Float Gauges (Ball Gauge)

Lever and shaft float gauges are normally used in pressurized / un-pressurized vessels with the small range of level must be measured. The range of measurement is determined by the length of the float arm. Ball float devices use a principle similar to the torque tube in the displacer to eliminate the stuffing box.

These are widely used for on-off service, operating valves or alarms in applications such as high levels in compressor and fuel gas knock-out drums and distillate drums, where dependable action at infrequent intervals is necessary. The flattened section of the ball arm allows sufficient motion to be transferred out of the pressure zone to operate a pneumatic or electric switch.

These design guideline are believed to be as accurate as possible, but are very general and not for specific design cases. They were designed for engineers to do preliminary designs and process specification sheets. The final design must always be guaranteed for the service selected by the manufacturing vendor, but these guidelines will greatly reduce the amount of up front engineering hours that are required to develop the final design. The guidelines are a training tool for young engineers or a resource for engineers with experience.

This document is entrusted to the recipient personally, but the copyright remains with us. It must not be copied, reproduced or in any way communicated or made accessible to third parties without our written consent.

KLM Technology Group Practical Engineering Guidelines for Processing Plant Solutions	SECTION :	Page 28 of 58
	INSTRUMENTATION	Rev: 03
	(ENGINEERING DESIGN GUIDELINE)	November 2010

Level instruments using a ball float on a lever arm operating a standard controller or switch require a stuffing box, and are now considered obsolete. They have generally been replaced by the displacer.

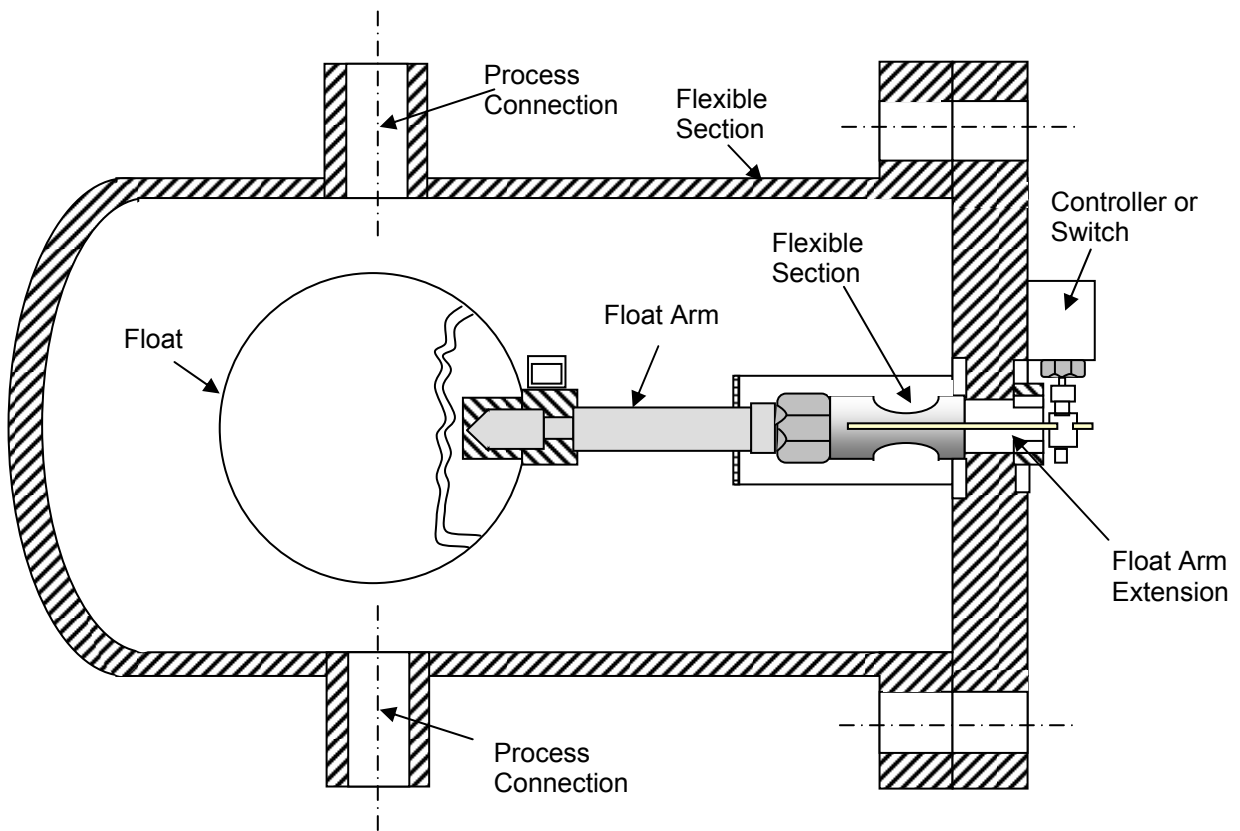

Figure 13: External Ball Float Level Device for Emergency and Alarm Services

System shown in Figure 13 is almost exclusively for alarms, cut-in and cutout services satisfied by 2-position control. This is usually a type that operates at the center of an external chamber; thus, no range. Normally the distance between taps is 24 in (609 mm), and minimum connection sizes of pipe is 2 in (50 mm) but for Alky Settlers is 10 in (254 mm).

These design guideline are believed to be as accurate as possible, but are very general and not for specific design cases. They were designed for engineers to do preliminary designs and process specification sheets. The final design must always be guaranteed for the service selected by the manufacturing vendor, but these guidelines will greatly reduce the amount of up front engineering hours that are required to develop the final design. The guidelines are a training tool for young engineers or a resource for engineers with experience.

This document is entrusted to the recipient personally, but the copyright remains with us. It must not be copied, reproduced or in any way communicated or made accessible to third parties without our written consent.

KLM Technology Group Practical Engineering Guidelines for Processing Plant Solutions	SECTION : INSTRUMENTATION (ENGINEERING DESIGN GUIDELINE)	Page 29 of 58
		Rev: 03
		November 2010

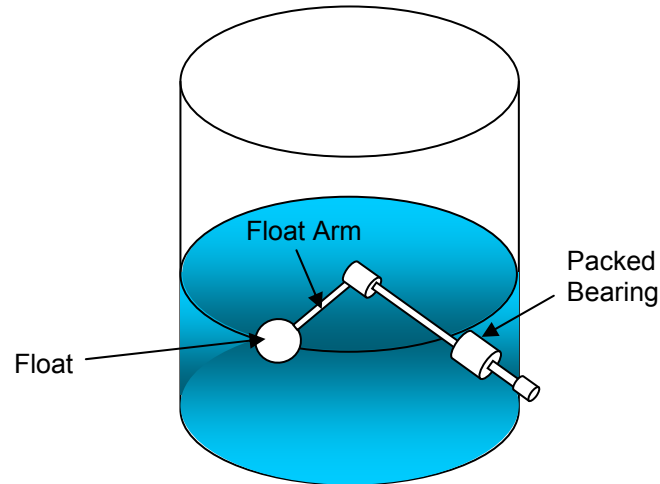

Figure 14: Internal Ball Float Level Device

Generally for internal ball float level device the measurement range same at the external ball float level device. This device normally used for control the level of water in basin for the cooling water tower.

Displacer

Displacers measure the change in buoyancy of a solid body that is partially submerged in the liquid. Buoyancy is equal to the weight of the volume of liquid displaced. By varying the cross-section of the displacer (volume per unit length) the linear change in level can be measured for a variety of ranges.

The success of the displacer is due to the development of a suitable torque tube, which translates the resultant buoyancy into an upward movement and allows the motion of the displacer [less than 1 in. (25.4 mm)] to be transmitted outside the process pressure zone without a stuffing box or similar seal. The torque tube has the elastic properties that permit it to twist as the displacer tries to float. This device normally limited to measure level height up to 3 meter only.

These design guideline are believed to be as accurate as possible, but are very general and not for specific design cases. They were designed for engineers to do preliminary designs and process specification sheets. The final design must always be guaranteed for the service selected by the manufacturing vendor, but these guidelines will greatly reduce the amount of up front engineering hours that are required to develop the final design. The guidelines are a training tool for young engineers or a resource for engineers with experience.

This document is entrusted to the recipient personally, but the copyright remains with us. It must not be copied, reproduced or in any way communicated or made accessible to third parties without our written consent.

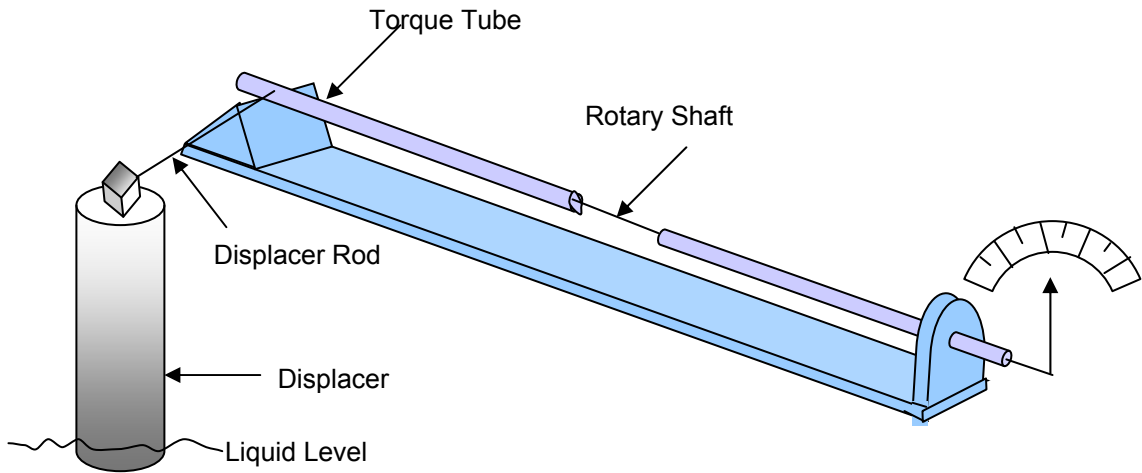

Figure 15: Displacer Level Measuring Device

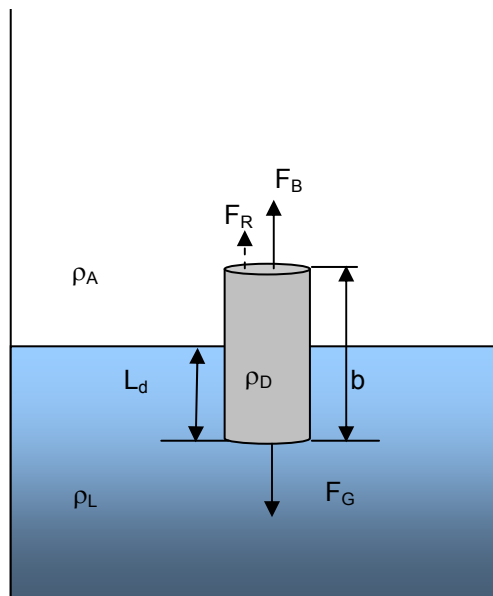

Figure 16: Quantities of A Solid Body Immersed into A Liquid

These design guideline are believed to be as accurate as possible, but are very general and not for specific design cases. They were designed for engineers to do preliminary designs and process specification sheets. The final design must always be guaranteed for the service selected by the manufacturing vendor, but these guidelines will greatly reduce the amount of up front engineering hours that are required to develop the final design. The guidelines are a training tool for young engineers or a resource for engineers with experience.

This document is entrusted to the recipient personally, but the copyright remains with us. It must not be copied, reproduced or in any way communicated or made accessible to third parties without our written consent.